



MONROE COUNTY HIGHWAY DEPARTMENT
803 WASHINGTON STREET
SPARTA, WISCONSIN 54656
(608) 269 - 8740 / 269 - 8831 (FAX)
highways@co.monroe.wi.us

DAVID H. OHNSTAD
HIGHWAY COMMISSIONER
WILLIAM PIEPER
FLEET MANAGER
BROOKE ADAMS
OFFICE MANAGER

DRIVEWAY APPLICATION for COUNTY TRUNK HIGHWAYS

WISCONSIN STATUTES 86.05 provides that "Whenever it is necessary, in making any highway improvement to cut or fill or otherwise grade the highway in front of any entrance to abutting premises, a suitable entrance to the premises shall be constructed as a part of the improvements; and if the premises are divided by the highway, then one such entrance shall be constructed on each side of the highway. Thereafter, each entrance shall be maintained by the owner of the premises. During the time the highway is under construction, the state, county, city, village or town shall not be responsible for any damage that may be sustained through the absence of an entrance to such premises".

WISCONSIN STATUTE 86.07(2) provides in part that "No person shall make any excavation or fill or install any culvert or make any other alteration in any highway or in any manner disturb any highway or bridge without a permit therefor from the highway authority maintaining the highway. Such permit shall contain the statement and be subject to the condition that the work shall be constructed subject to such rules and regulations as may be prescribed by said authority and be performed and completed to its satisfaction,"

In summary, the County Highway Department is obligated to provide a driveway to private property only when making major grading improvements past an existing entrance. At all other times, the property owner is responsible for installation of new driveways and repairs to or replacement of existing driveways per State Statutes and Monroe County Ordinance 8.03.

Attached is a permit application for new driveways. Using a ballpoint pen, fill in the Application, and return to this office with the \$135 permit fee {per Monroe County Ordinance 8.03(1)}. A representative of this office, as soon as our workload allows, will inspect the site and return the permit to you. If you are unable to be present during this site inspection, it will help greatly if you will mark the exact site(s) with stakes in the ditch line. Culverts, if needed, do not have to be new but must be in good condition with a minimum diameter of 15" and 30 ft in length.

If you have any questions, please do not hesitate to call the Highway Department office at the phone number listed above.

David Ohnstad
Highway Commissioner

DRIVEWAY APPLICATION & PERMIT

MONROE COUNTY HIGHWAY DEPARTMENT

803 WASHINGTON STREET

SPARTA, WI 54656

Phone # 608-269-8740

highways@co.monroe.wi.us

Name of Applicant: _____ Phone No: _____

Email Address: _____

Present Mailing Address: _____ City: _____ State: _____ Zip: _____

County Trunk Highway Involved: _____ Number of Driveways: _____

Type of Driveway Requested: Residential ___ Agricultural ___ Proposed Road ___ Other _____

Township of _____; _____ 1/4, of the _____ 1/4, of Section _____

Approximate location of driveway: (Provide name of nearest road intersection and distance from that intersection): _____

On which side of Highway will driveway be located? _____

Has property been surveyed or subdivided? Yes ___ No _____

Certified Survey Map No: _____ Vol: _____ Page: _____

Unusual features of driveway request: (i.e. wider driveway for school bus, visibility, etc.) _____

**APPLICANT WILL PLACE STAKES IN DITCHLINE WHERE DRIVEWAY IS PROPOSED,
SO THAT HIGHWAY DEPARTMENT PERSONNEL CAN INSPECT LOCATION.**

I, the undersigned applicant do hereby certify that I have requested this driveway permit and that I have read, understand, and agree to abide by all the applicable provisions and restrictions which are shown on the reverse side of this application.

Please read owner's covenant on reverse side.

Owner's Signature

Date: _____

-OWNER'S COVENANT-

I have read, understand, and hereby agree to abide by the following special regulations and provisions of this permit:

- A. The entire cost of the driveway construction, installation and/or replacement shall be the responsibility of the applicant.
- B. Any grading, special ditching, alteration of slopes, or any other disturbance of any portion of the highway right-of-way, shall be restored by and at the expense of the applicant, to the condition existing prior to such disturbance and to the satisfaction of the County Highway Department. If the restoration work or any damage caused to highway right-of-way by the applicant cannot or will not be accomplished voluntarily, the highway Department will complete the required work at the applicant's expense.
- C. The applicant shall keep the driveway culvert free of debris and other obstructions in order to provide proper drainage along the highway. If the culvert fails (caves in or is rusted through) it shall be promptly replaced.
- D. The maintenance and upkeep of driveway(s) on and over County Trunk Highway right-of-way shall be the responsibility of the owner.
- E. The Permittee, his/her successors, or assigns, agree to hold harmless the Monroe County Highway Department and its duly appointed agents and employees against any actions for personal injury or property damage sustained by reasons of the issuance or exercise of this permit.

(To be filled out by Highway Department Personnel)

Size of Culvert? _____ Length of Culvert required? _____ If no culvert, state why? _____

Is adequate clear vision available looking both ways from proposed driveway? Yes _____ No _____

Is driveway entrance within 200 feet of an intersection or bridge? Yes _____ No _____

Additional Requirements: _____

Date checked: _____ By: _____

Permit Approved: _____ Date: _____

\$135 Permit Fee Paid? No Yes (Cash Receipt #, Check # _____)

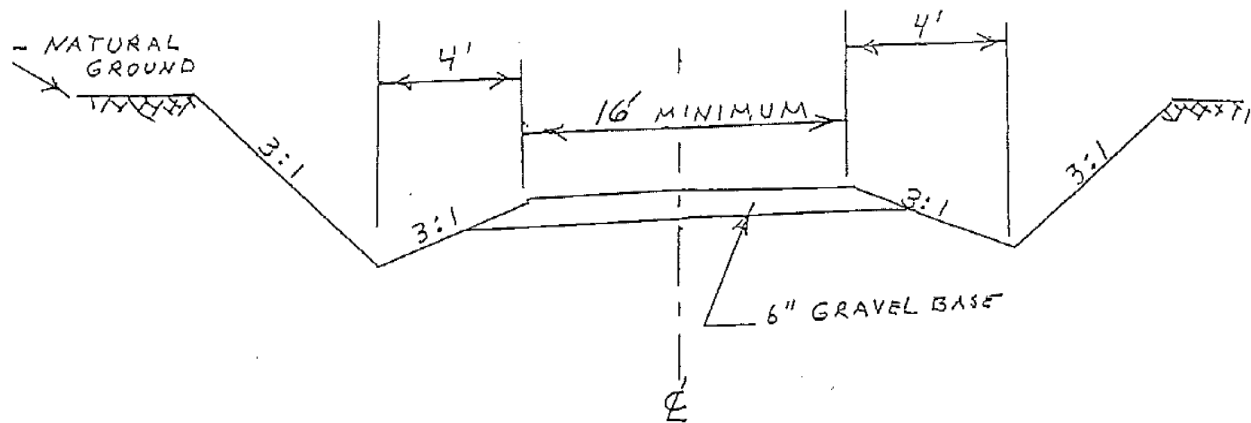

TYPICAL CROSS SECTION FOR PRIVATE DRIVE OR FIELD ENTRANCE

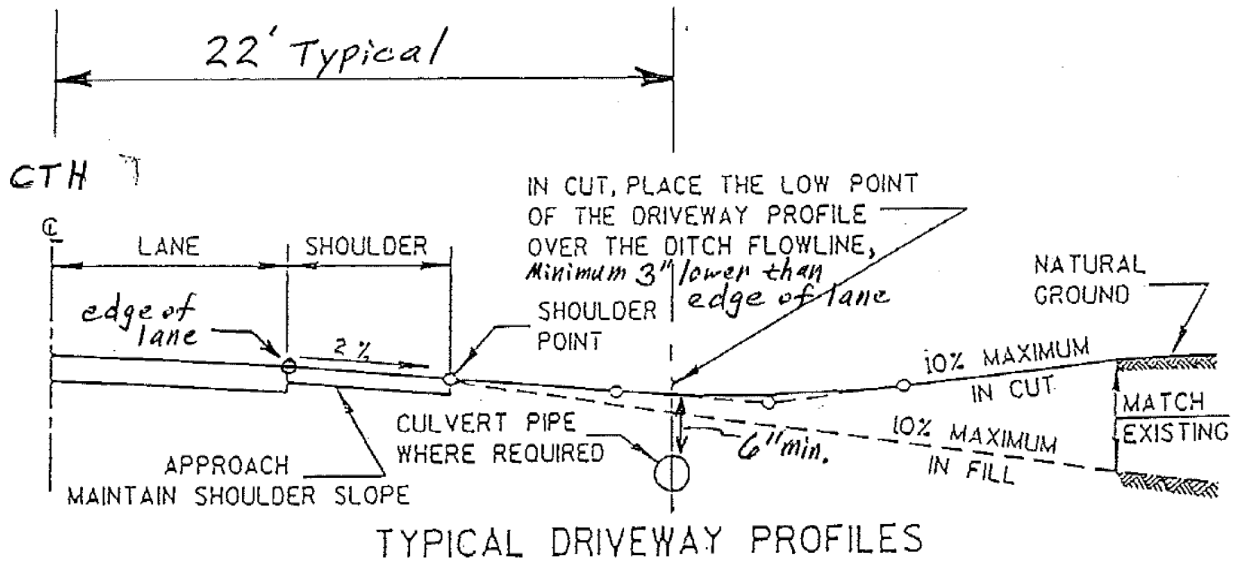

GENERAL NOTES:

CTH ditch may need to be graded/dug to get drainage into and out of new culvert

Owner is responsible for cleaning out CTH ditch if erosion from driveway fills it in